

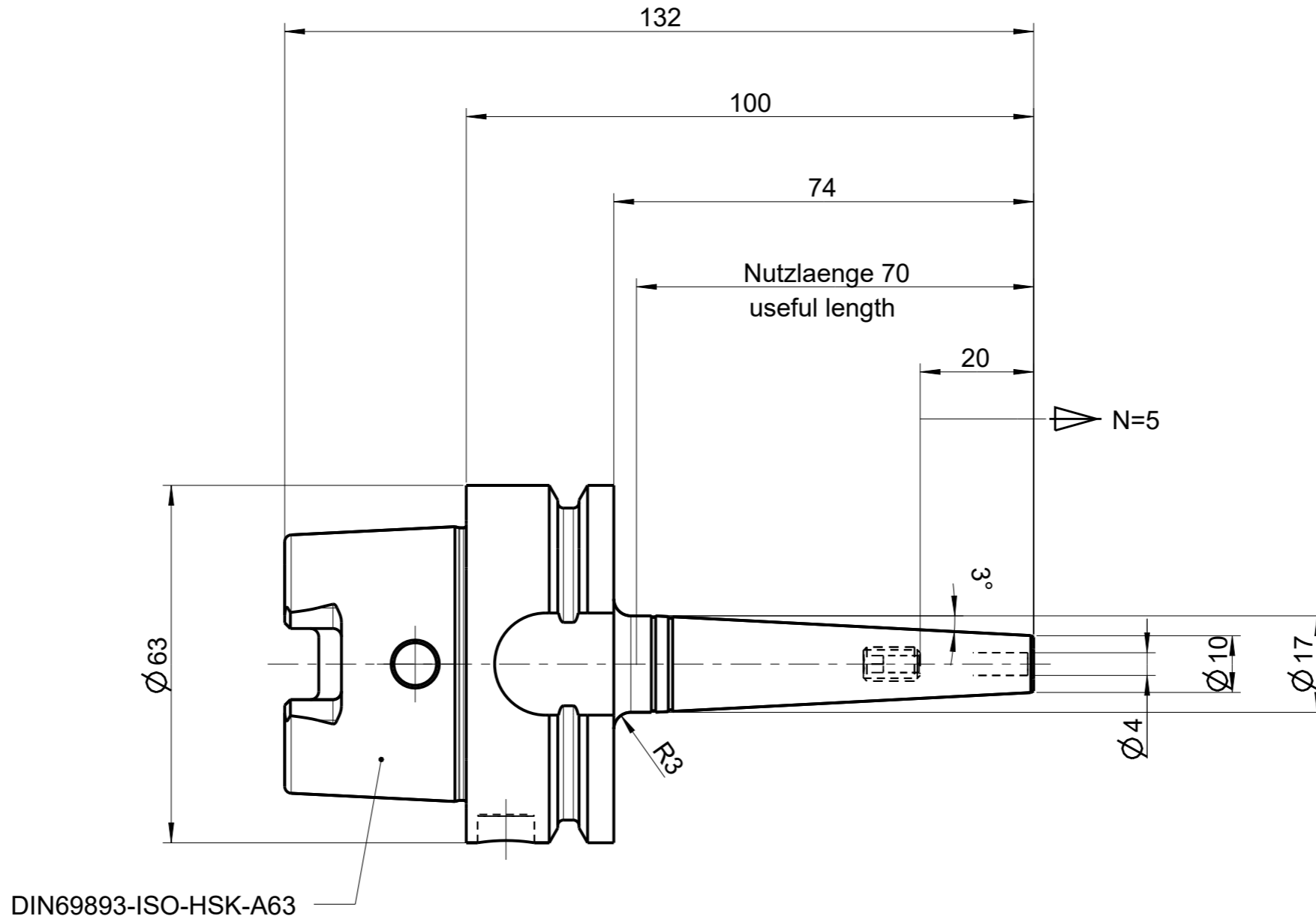

Weitergabe sowie Vervielfältigung dieser Zeichnung, Verwertung und Mitteilung seines Inhaltes sind verboten, soweit nicht ausdrücklich gestattet. Zuwiderhandlungen verpflichten zu Schadensersatz. Alle Rechte für den Fall der Patent-, Gebrauchsmuster- oder Geschmacksmusterertragung vorbehalten. The reproduction, distribution and utilization of this drawing as well as the communication of this contents to others without express authorization is prohibited. Offenders will be held liable for the payment of damages. All rights reserved in the event of the grant of a patent, utility model or design.

DIN A3 MB CREO 4



technische Aenderungen vorbehalten / subject to technical alterations				 Gewicht/weight= 0.716 kg				
Schutzvermerk ISO 16016 beachten / refer to protection notice ISO 16016								
Modell 5.0	Freigegeben	Maßstab scale	A3	Datum	Name			
Zeichnung 6.1	Freigegeben		Konst.	25.01.06	BS			
9		1:1	Gez.	11.03.24	MC			
8			Gepr.					
7			 Spannfutter System ThermoGrip Clamping chuck ThermoGrip system					
6								
5	146/2023						11.03.24	MC
4	31/2014						22.05.14	MH
3	64/2011						05.01.12	MO
2	67/2007		03.04.08	MT				
1	28/06 ; 54/06		04.10.06	MT				
Nr. no.	Aenderung change	Datum date	Name					
			Ident Nr. 9078655	Bezeichnung / designation TSF0400-70/HSK-A63				
			Zeichnungsname: 9078655-M		Blatt sheet 1/1			
				Aenderungen nur im CAD / changes only in CAD				